

---

# Vattenkvalitet vid substrattillverkning

Marie-Louise Fock,  
Merck Millipore, Lab Water

# Agenda

---

**Water Contaminants**

**Pure Water Definitions**

**Water for culture media  
preparation**

# Water Contaminants

---

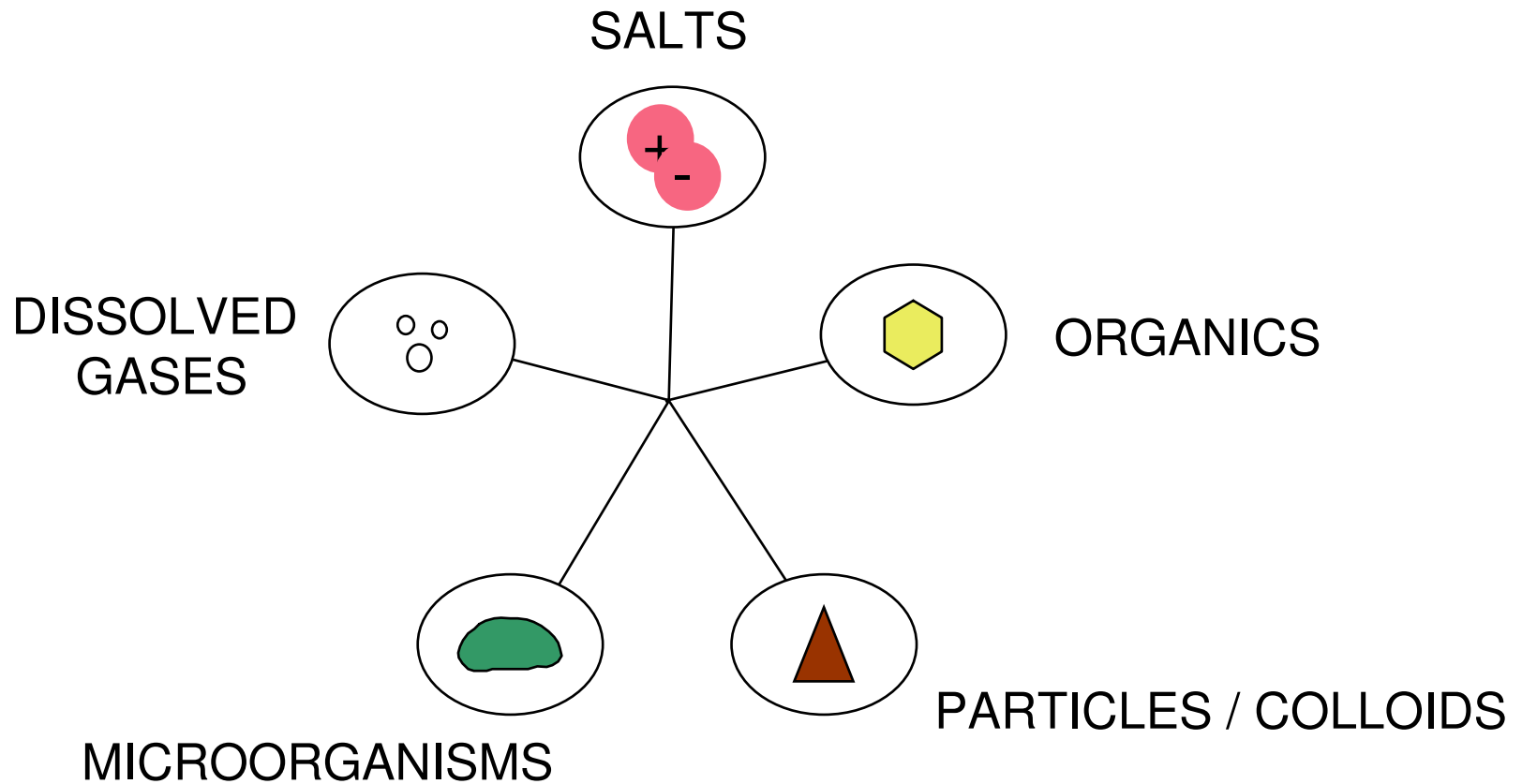

# Common salts in Tap water

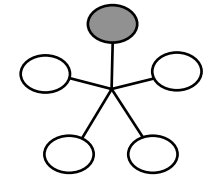

## ANIONS

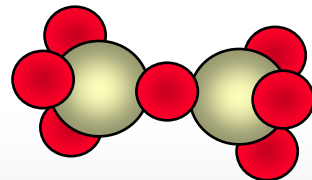
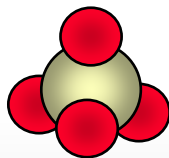
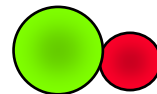
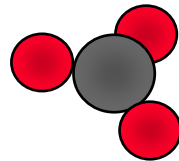
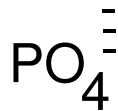
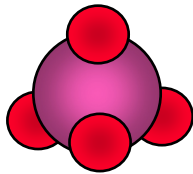
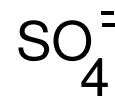
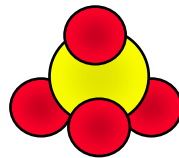
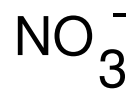
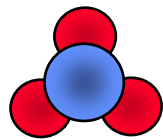
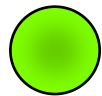

## CATIONS

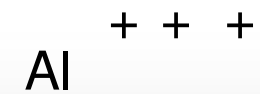
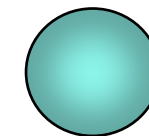
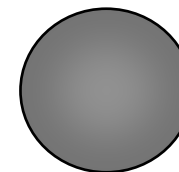
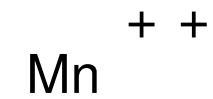
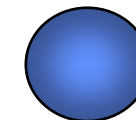
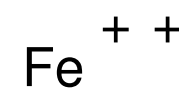
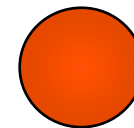
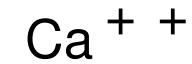
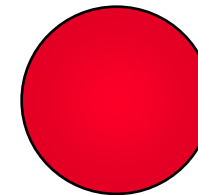
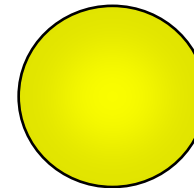

# Organic Solutes (natural)

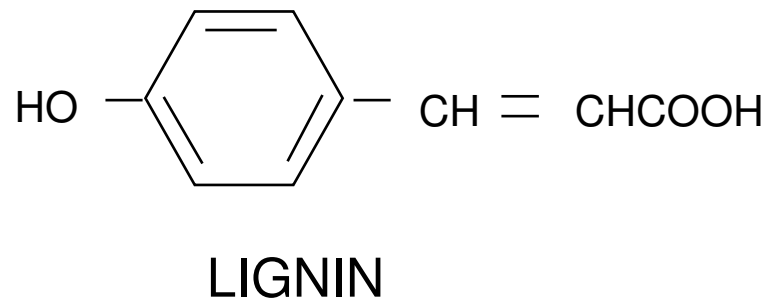
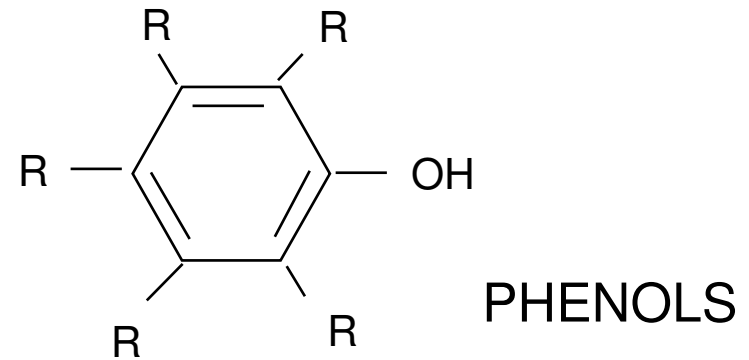
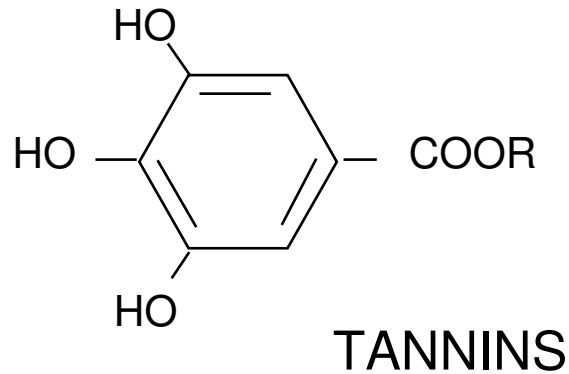
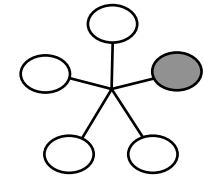

HUMIC ACIDS

FOLIC ACIDS

PYROGENS

# Organic Solutes (artificial)

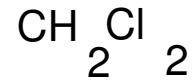
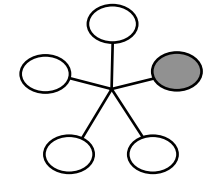

ORGANOCHLORINE

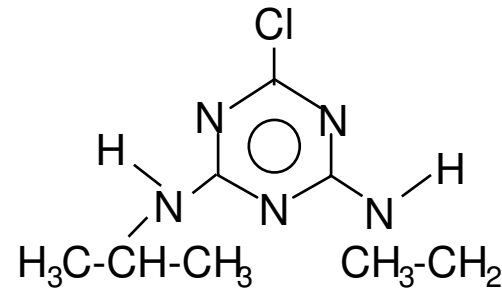

HERBICIDES

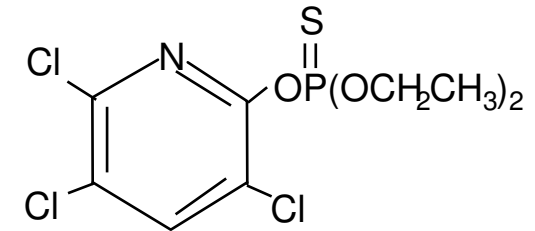

INSECTICIDES

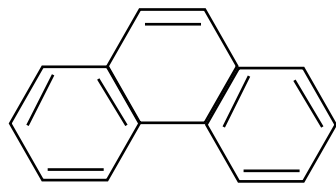

PAH

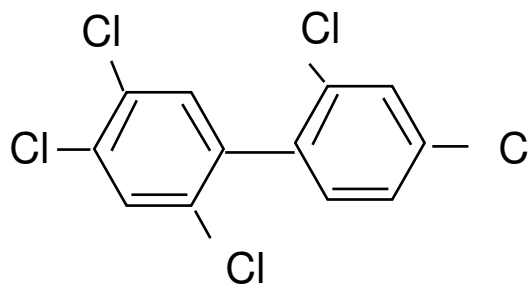

PCB

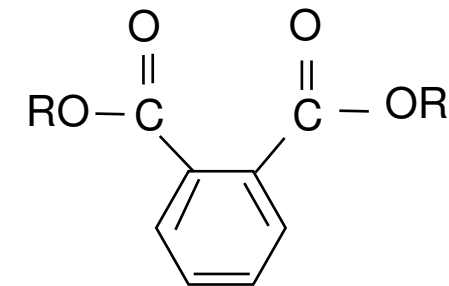

PHTALATES

# Particles and Colloids

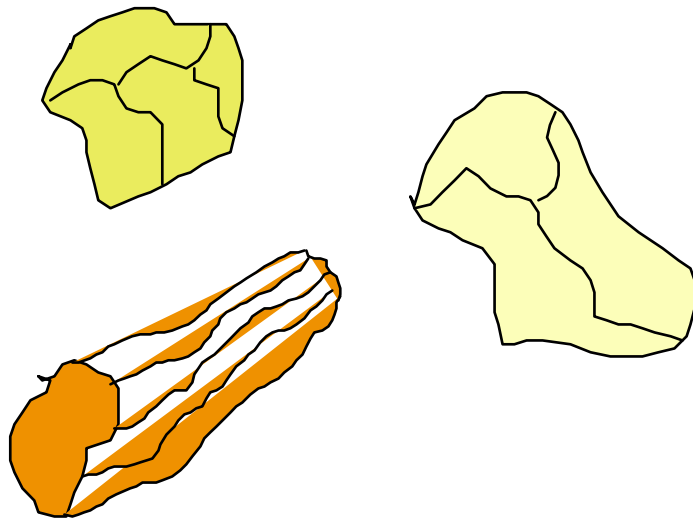
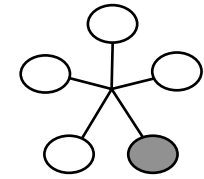

Hard or Soft Particles :  
a protection for bacteria  
and a nuisance in lab  
experimentation

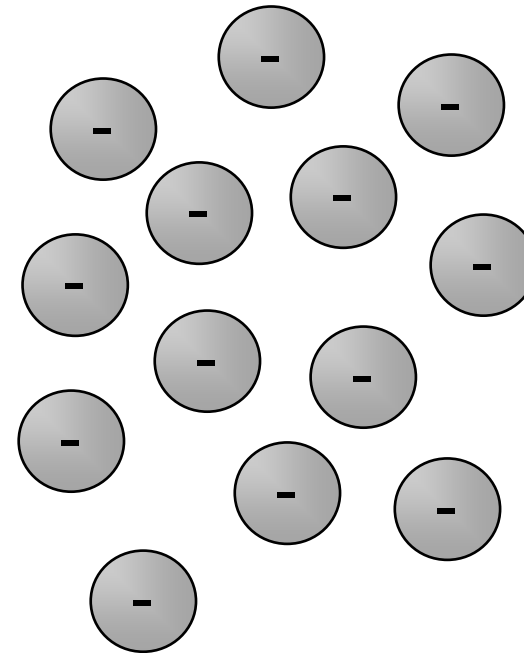

Colloids :stable suspension  
of inorganic or organic  
particles

# Microorganisms

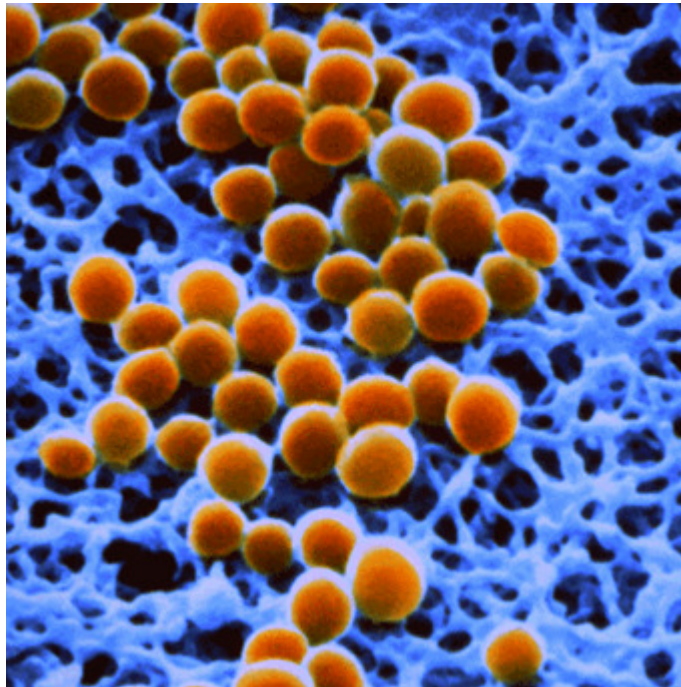
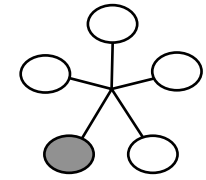

Endotoxin

Lipopolysaccharide fragment of Gram negative bacterial cell wall

# Gases

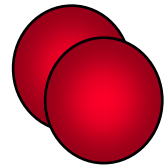
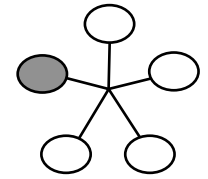

Oxygen

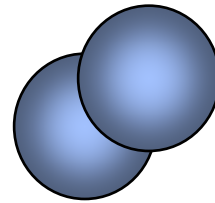

Nitrogen

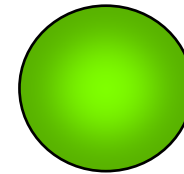

Radon

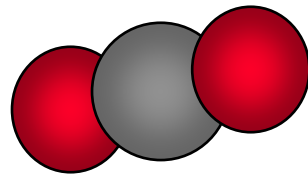

Carbon  
Dioxide

# Föroreningar ger problem

---

- |                          |                                    |
|--------------------------|------------------------------------|
| → Joner                  | Inhibering<br>Utfällningar         |
| → Organiska föroreningar | Bakterietillväxt<br>Inhibering     |
| → Partiklar/Kolloider    | Bakterietillväxt                   |
| → Gaser                  | Koldioxid ger svagt<br>surt vatten |

# Agenda

---

**Water Contaminants**

**Pure Water Definitions**

**Water for culture media**

# Pure Water Definitions-conductivity

---

**Ionic contamination**

**Conductivity = 1 / Resistivity**

**Conductivity unit:  $\mu\text{S}/\text{cm}$**

**Resistivity unit:  $\text{M}\Omega\text{cm}$**

**Conductivity is temperature dependent.**

**We always express it at + 25 °C**

# Pure Water definitions-conductivity

---

- **Type I - Ultrapure water - Milli-Q**
  - Resistivity 18.2 MΩcm at + 25 °C
- **Type II - Analytical Grade Water - Elix**
  - Resistivity > 1 MΩcm at + 25 °C
  - Conductivity < 1 μS/cm at + 25 °C
- **Type III - General Laboratory Grade Water - RiOs**
  - Conductivity 2-50 μS/cm at + 25 °C

# Pure Water Definitions-TOC

- TOC - Total Oxidizable Carbon
- Tap water may contain hundreds of different organic substances
- TOC measurement is a way of normalizing the amount of organic compounds in water
- TOC monitoring will express the total organic contamination of water with a single figure

Organic breakthrough with no resistivity change

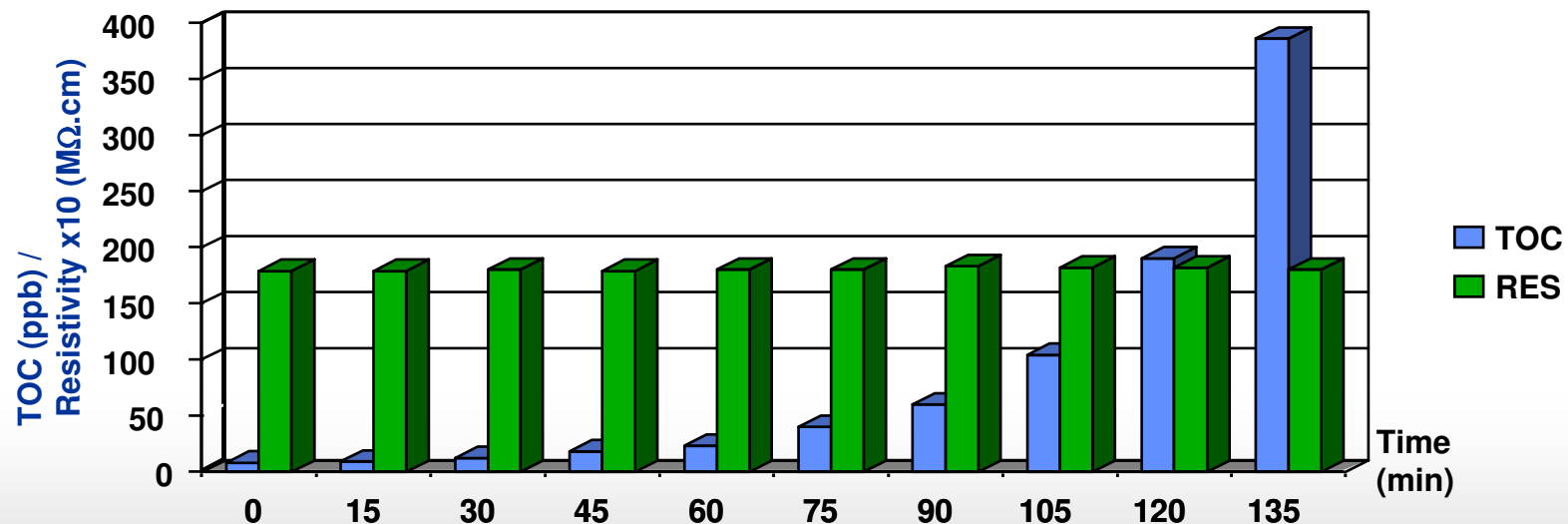

# Pure Water Definitions-TOC

---

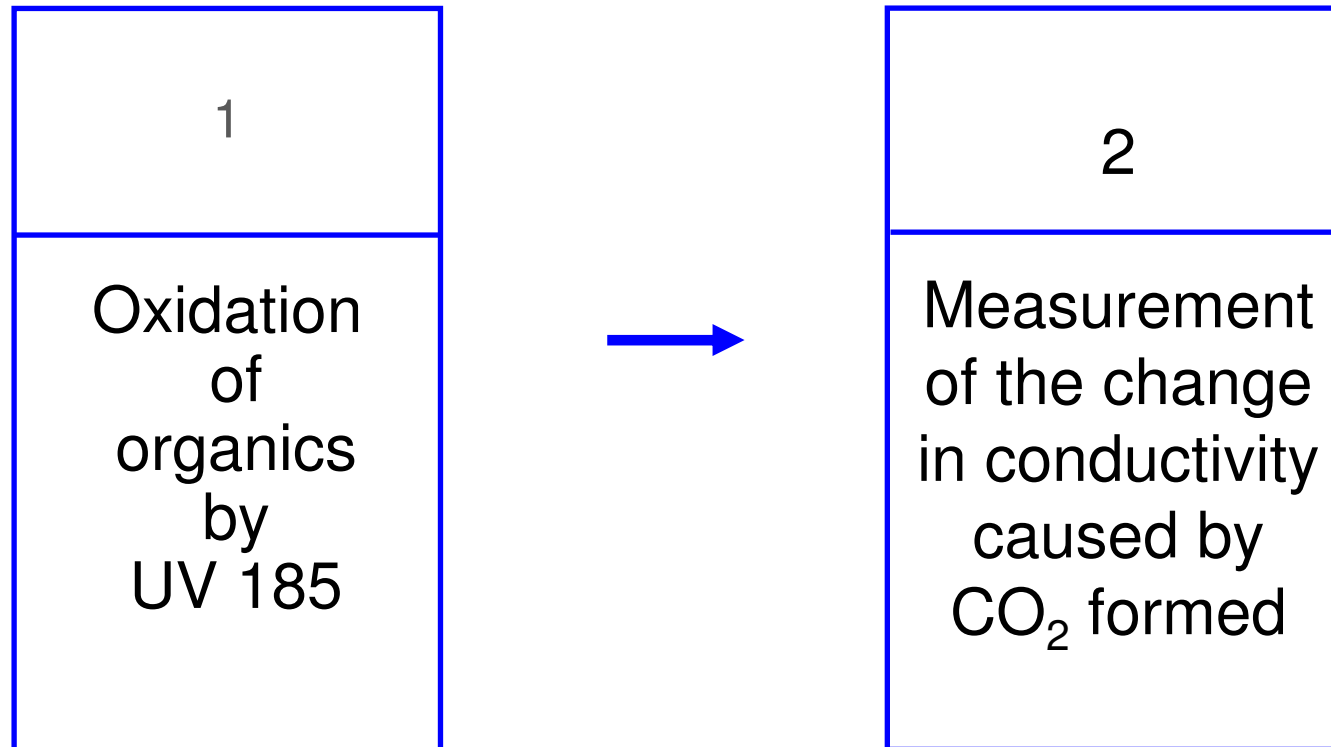

Process developed by Anatel

# Millipore Water Specifications

Contaminant	Parameter & unit	Type 3	Type 2	Type 1
Ions	Resistivity (MΩ.cm)	> 0.05	> 1.0	> 18.0
Organics	TOC (ppb)	< 200	< 50	< 10
	Pyrogens (Eu/ml)	NA	< 0.25	< 0.03
Particulates	Particulates > 0.2 μm (units / ml)	NA	NA	< 1
Colloids	Silica (ppb)	< 1000	< 100	< 10
Bacteria	Bacteria (cfu/ml)	< 1000	< 100	< 1

# Water Purification Techniques

---

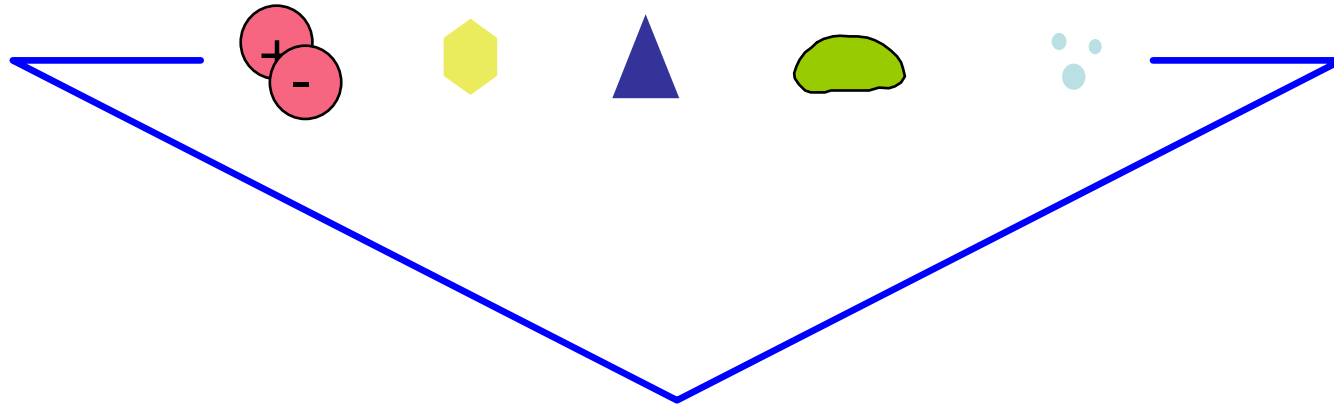

Contaminants Removal By							
Still	RO	DI	EDI	UF	MF	AC	UV

# A combination of technologies to produce ultrapure water

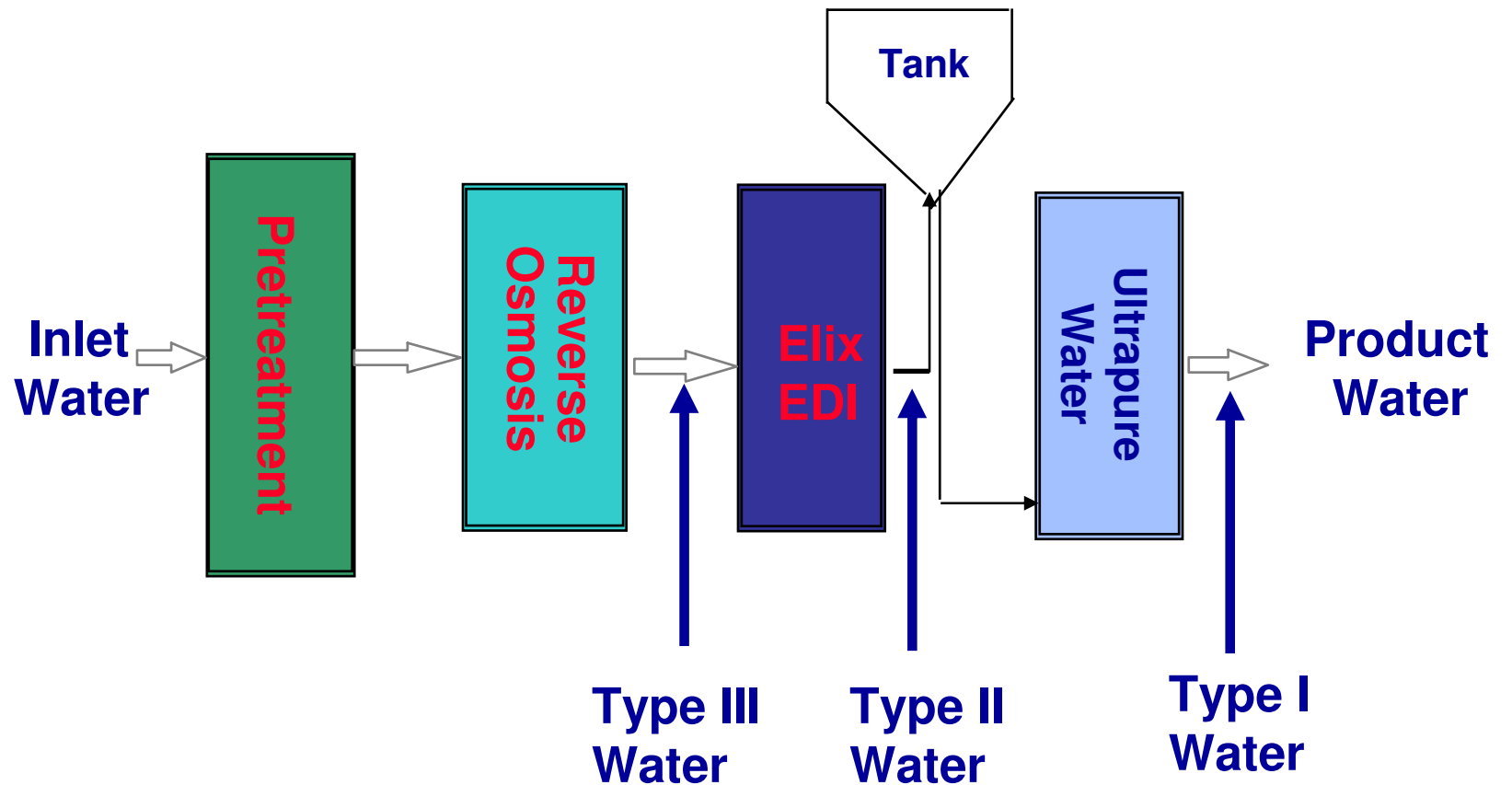

# Agenda

---

**Water Contaminants**

**Pure Water Definitions**

**Water for culture media**

## Saker att tänka på....

---

- Kontroll av vattenkvaliteten      Konduktivitet, bakterier, endotoxiner, TOC
- Undvika tillväxt i vattenreningsutrustningen      Rätt system ev. med UV-ljus  
Slutfilter för bakteriefritt vatten  
Underhåll
- Undvika lagring av vatten      Koldioxid surt pH  
Tillväxt av bakterier  
Urlakning av ämnen
- Använda nytillverkat vatten

# Milli-Q Advantage A10

---



# Standard purification steps

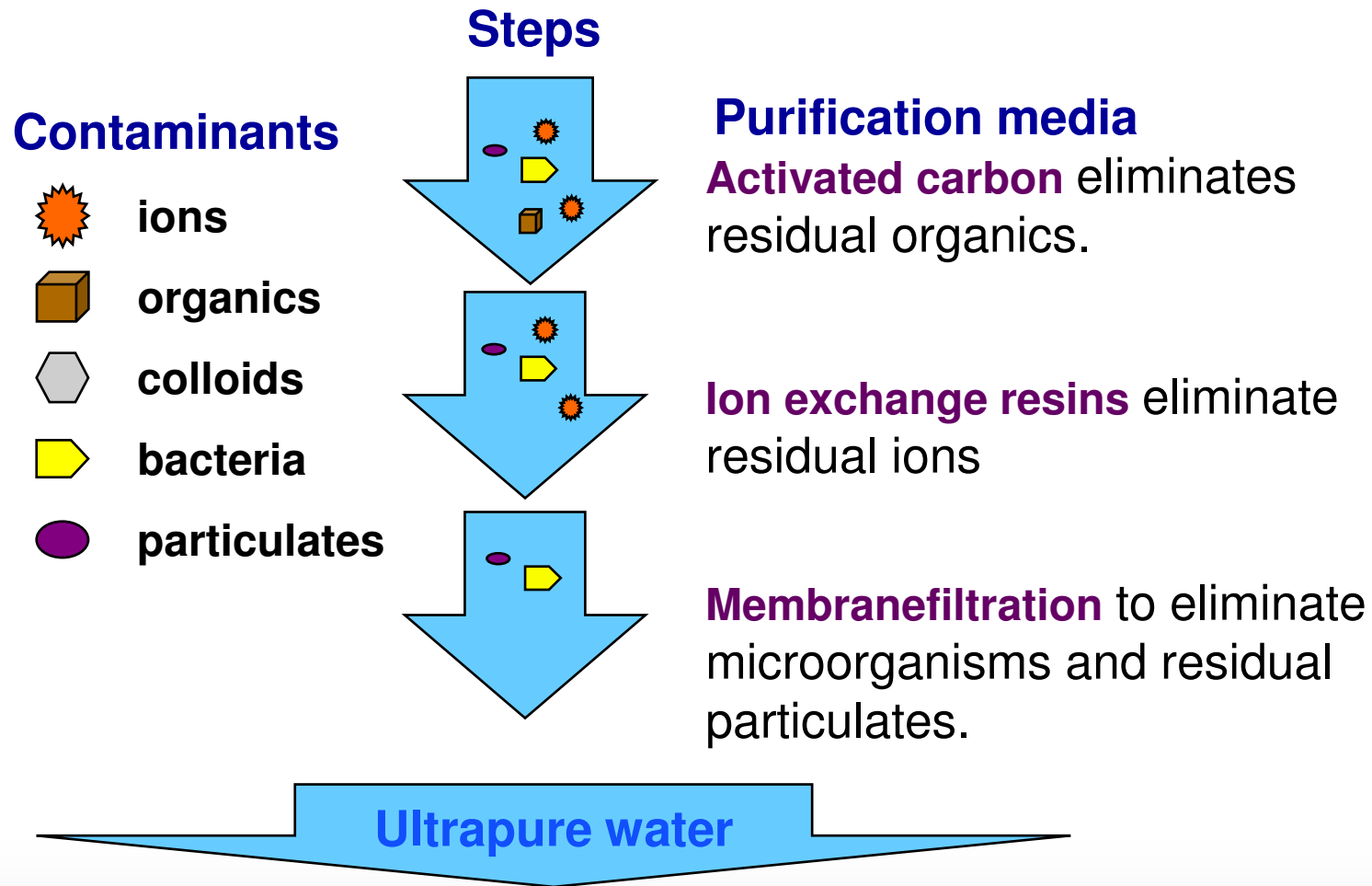

# UV-lamp

- Germicidal action
- Removal of organics by photo-oxidation

**Germicidal Action (254 nm)**

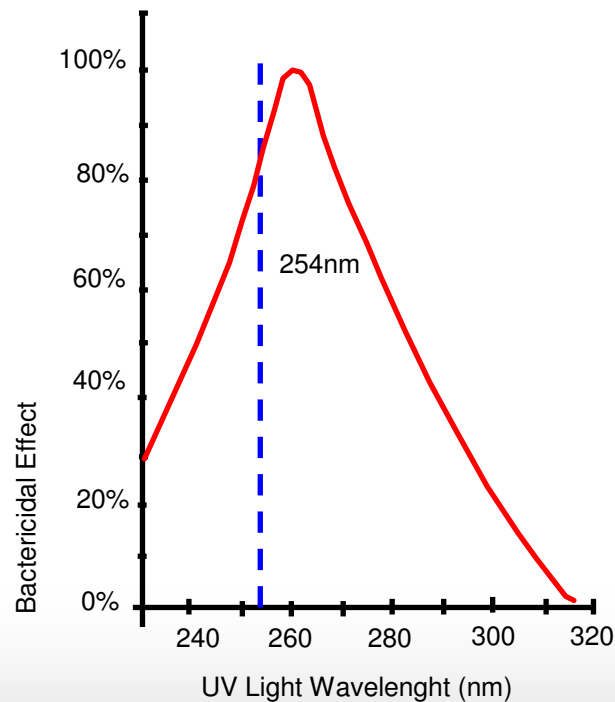

**UV action on Organic Contaminants**

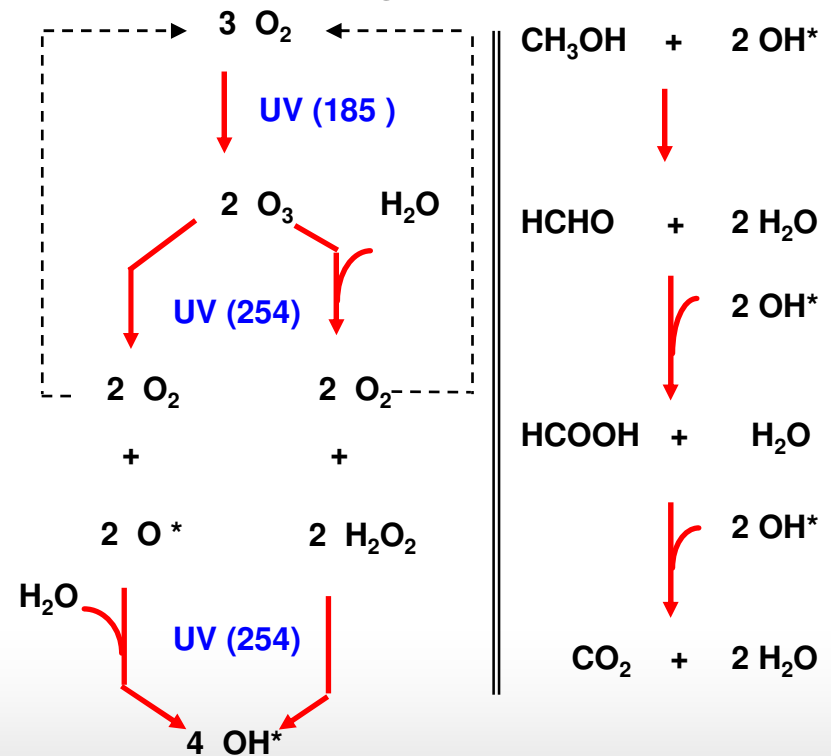

# Milli-Q Advantage

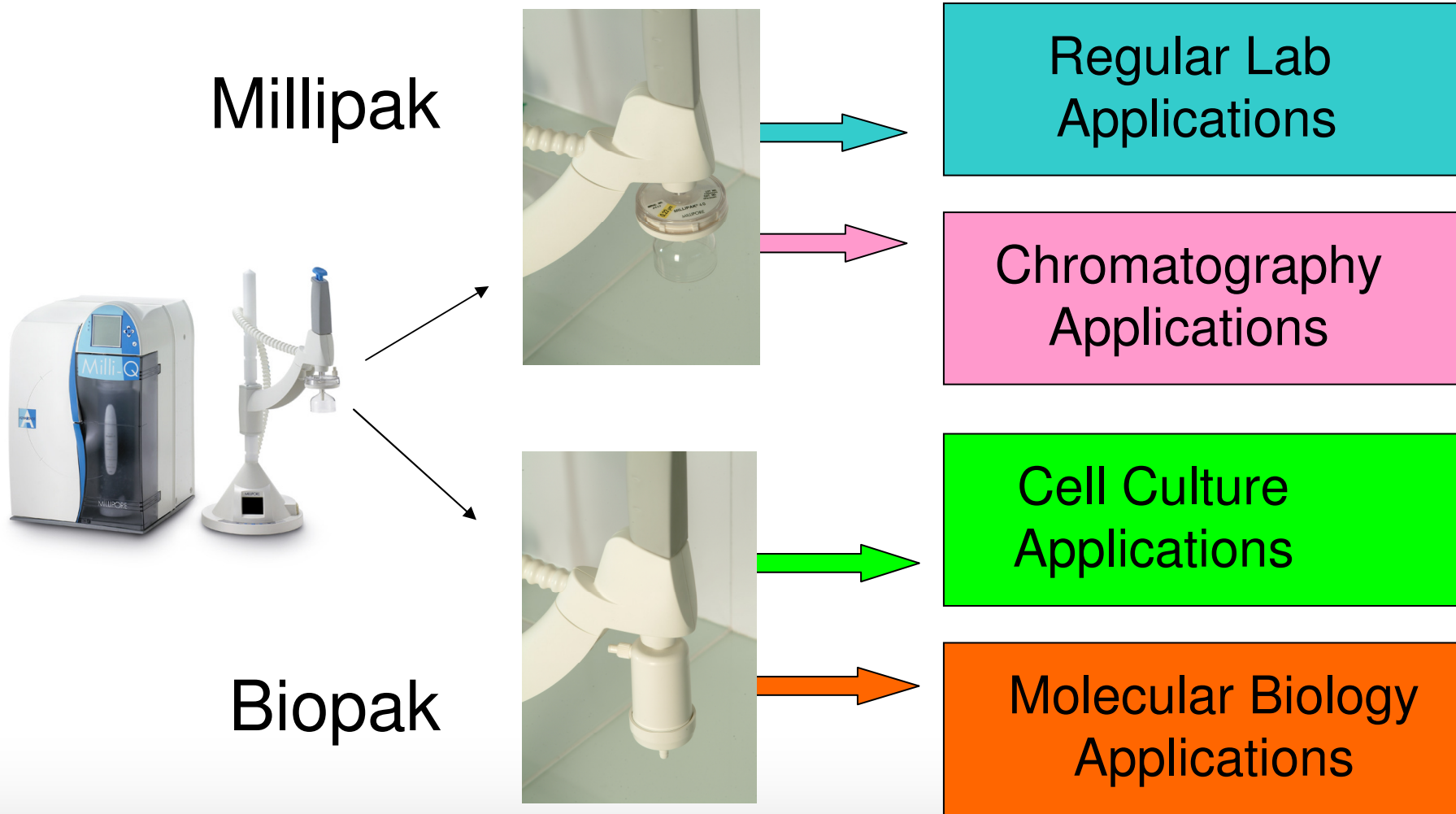

# Final Filter: BioPak ultrafilter

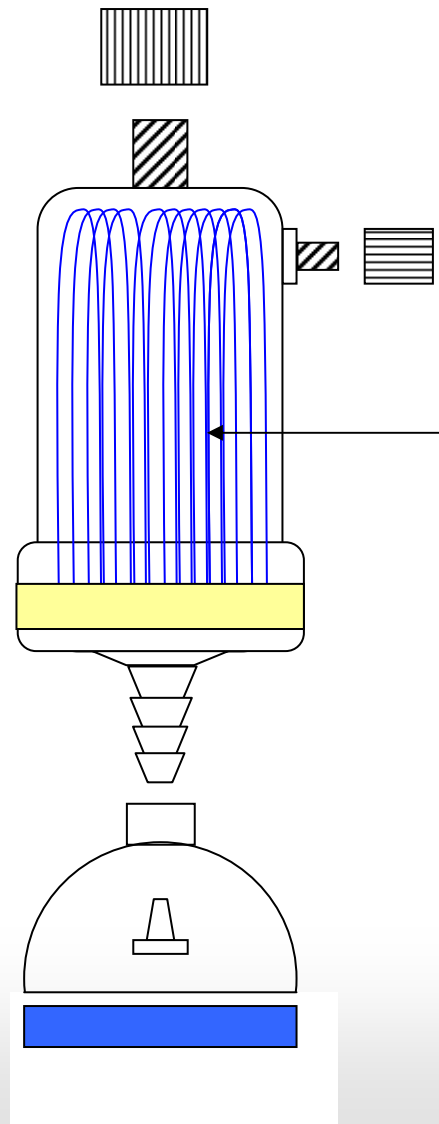

BioPak, hollow fiber ultrafilter, for endotoxin- and nuclease-free water

# Q-Pod Polishers

---



# Water Quality Display

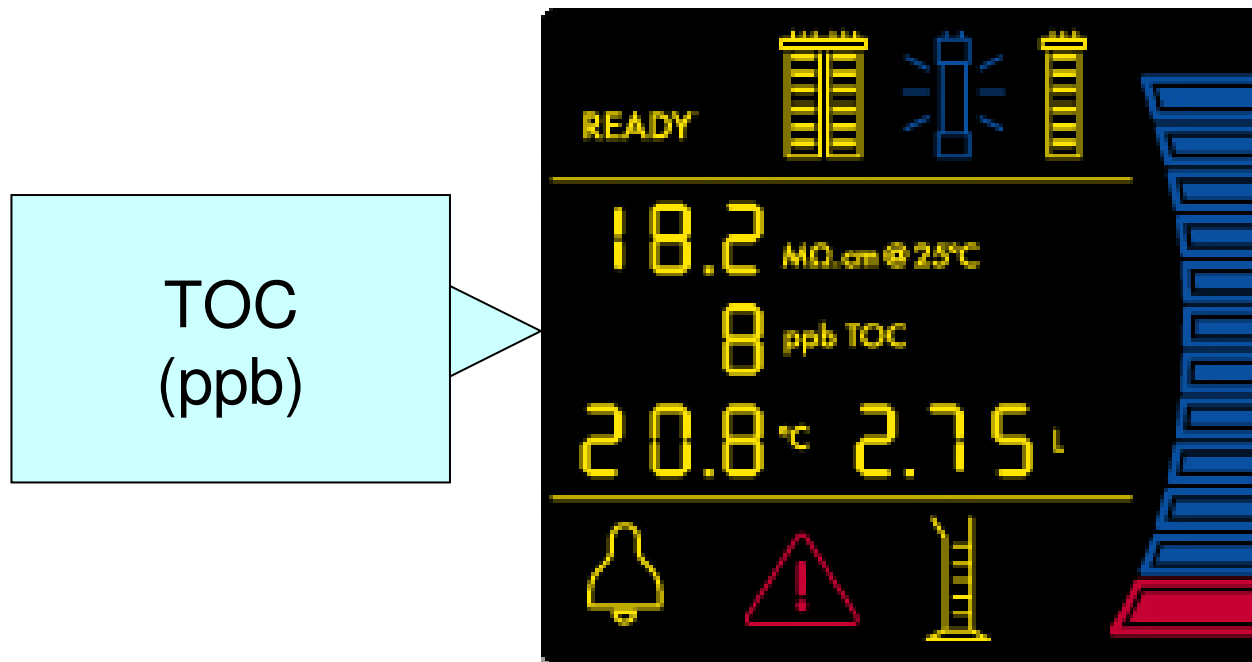

# Measuring the pH of Ultrapure Water

---

- It is not possible to measure the pH of ultrapure water with conventional pH meters .
- There are not enough ions to allow the meter to function properly.
- Carbon dioxide from the atmosphere will quickly dissolve in water and decrease pH
- As a conclusion: do not attempt to measure the pH of ultrapure water. Anyway, the pH of ultrapure water (resistivity = 18.2 Megohm.cm @ 25°C) is always is 7.0 at 25 °C (\*)
  - (\*)Actually: 6.998
- **Solutions :**
  - Measure in-line with addition of neutral salt (KCl)
  - Simply do not measure pH  
A resistivity of 18 MΩ.cm is a guarantee of a neutral pH

# Ultrapure Water Stored in Glass

---

